

外形尺寸图 (Overall Dimension) :

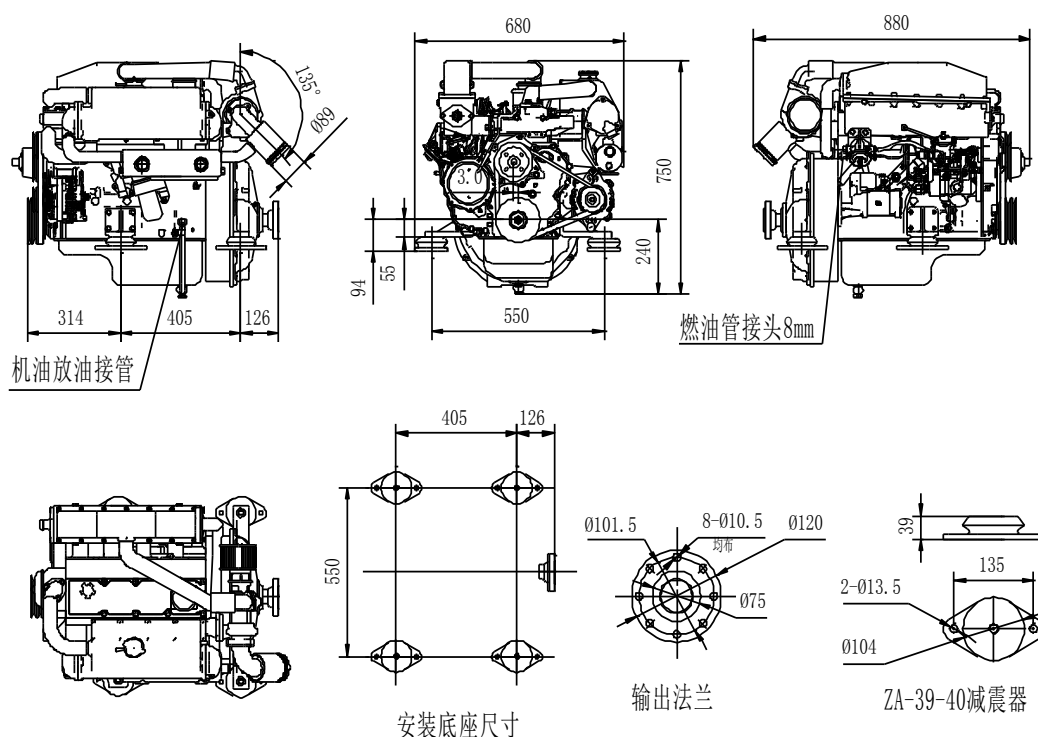

SY144C 外形安装图

主要技术参数 (Main Technical Data) :

型号 Model	SY110C	SY144C
型式 Type	四缸、直立、四冲程、水冷 涡流式、增压 Four cylinders, In-line, vertical, four stroke, water cooling, swirl injecting, turbo charger	四缸、直立、四冲程、水冷 涡流式、增压中冷 Four cylinders, In-line, vertical, four stroke, water cooling, swirl injecting, turbo inter-cooling
缸径 X 冲程 Cylinder bore X stroke (mm)	99.2X102	
活塞总排量 Total piston displacement (L)	3.153	
压缩比 Compression ratio	22:1	
标定功率/转速 Rated power/speed (KW/r/min)	73.6(100PS)/3600	96(130.6PS)/3600
最大功率/转速 Max. power/Rated (KW/r/min)	80.9(110PS)/3715	105.6(143.6PS)/3715
起动方式 Starting method	电起动 (可加一套起动装置) Electric(with two sources)	
输出旋向 (面对飞轮) Direction of rotation(From flywheel)	逆时针 Anti-clockwise	
外形尺寸 (长 X 宽 X 高) Engine overall dimension (mm)	880×680×715	880×680×750
净质量 Net weight (Kg)	285	296